True Ground Speed Sensor

TGSS

User Guide

MSG33-5005-IB/US

UG-TGSS-740051-201908-003

Parker Hannifin Canada
Electronic Controls Division
1305 Clarence Avenue
Winnipeg, MB R3T 1T4 Canada
office +1 204 452 6776
Fax +1 204 478 1749

<http://www.parker.com/ecd>

Copyright 2019 © Parker Hannifin Corporation. All rights reserved. No part of this work may be reproduced, published, or distributed in any form or by any means (electronically, mechanically, photocopying, recording, or otherwise), or stored in a database retrieval system, without the prior written permission of Parker Hannifin Corporation in each instance.

 **Warning!**

FAILURE OR IMPROPER SELECTION OR IMPROPER USE OF THE PRODUCTS AND/OR SYSTEMS DESCRIBED HEREIN OR RELATED ITEMS CAN CAUSE DEATH, PERSONAL INJURY AND PROPERTY DAMAGE.

- This document and other information from Parker Hannifin Corporation, its subsidiaries and authorized distributors provide product and/or system options for further investigation by users having technical expertise.
- The user, through its own analysis and testing, is solely responsible for making the final selection of the system and components and assuring that all performance, endurance, maintenance, safety and warning requirements of the application are met. The user must analyze all aspects of the application, follow applicable industry standards, and follow the information concerning the product in the current product catalog and in any other materials provided from Parker or its subsidiaries or authorized distributors.
- To the extent that Parker or its subsidiaries or authorized distributors provide component or system options based upon data or specifications provided by the user, the user is responsible for determining that such data and specifications are suitable and sufficient for all applications and reasonably foreseeable uses of the components or systems.
- The Buyer and/or end-user will be solely responsible for final disposal of all products.

Publication History

The following table provides an overview of the changes made to this document over the course of its publication history.

Revision	Description of Change
Rev. 001	First release of this document
Rev. 002	Update template and naming, 5/12/2017
Rev. 003	Update to meet RE-Directive requirements, 8/15/2019

Contents

Publication History	iii
Safety	v
Safety symbols	v
General safety regulations	v
Welding after installation	vi
Construction regulations	vi
Safety during installation	vi
Safety during start-up	vii
Safety during maintenance and fault diagnosis	vii
1. Product Description	8
1.1. TGSS	8
1.2. Compliances	9
2. Installation	10
2.1. Installation Guidelines	10
2.1.1. Mounting Bracket	11
2.1.2. Mounting Angle	12
2.1.3. Mounting the TGSS to a vehicle	12
2.1.4. Line of sight clearance	13
2.1.5. Installation Validation	15
2.2. Performance Considerations	16
3. Technical Specifications	17
3.1. Microwave Output	17
3.2. Speed Output Signal	17
3.3. Radar-Present Output	18
3.4. Connectors	18
4. Electrical Specifications	20
5. Environmental Specifications	21
6. Mechanical Specifications	22
6.1. Dimensions	23
7. Appendix A	24
7.1. TGSS Technical Overview	24

7.1.1. Environmental ratings24

8. Index..... 28

Safety

Do not perform the procedures in this manual unless you are experienced in the handling of electronic equipment.

Contact the manufacturer if there is anything you are not sure about or if you have any questions regarding the product and its handling or maintenance.

The term "manufacturer" refers to Parker Hannifin Corporation.

Safety symbols

The following symbols are used in this document to indicate potentially hazardous situations:

 *Danger! Risk of death or injury.*

 *Warning! Risk of damage to equipment or degradation of signal*

When you see these symbols, follow the instructions carefully and proceed with caution.

General safety regulations

Work on the hydraulics control electronics may only be carried out by trained personnel who are well-acquainted with the control system, the machine, and its safety regulations.

 Follow the manufacturer's regulations when mounting, modifying, repairing, and maintaining equipment. The manufacturer assumes no responsibility for any accidents caused by incorrectly mounted or incorrectly maintained equipment. The manufacturer assumes no responsibility for the system being incorrectly applied, or the system being programmed in a manner that jeopardizes safety.

 Do not use the product if electronic modules, cabling, or connectors are damaged or if the control system shows error functions.

 Electronic control systems in an inappropriate installation and in combination with strong electromagnetic interference fields can, in extreme cases, cause an unintentional change of speed of the output function.

Welding after installation

Complete as much as possible of the welding work on the chassis before the installation of the system. If welding has to be done afterwards, proceed as follows:

 Do not place the welding unit cables near the electrical wires of the control system.

1. Disconnect the electrical connections between the system and external equipment.
2. Disconnect the negative cable from the battery.
3. Disconnect the positive cable from the battery.
4. Connect the welder's ground wire as close as possible to the place of the welding.

Construction regulations

The vehicle must be equipped with an emergency stop which disconnects the supply voltage to the control system's electrical units. The emergency stop must be easily accessible to the operator. If possible, the machine must be built so that the supply voltage to the control system's electrical units is disconnected when the operator leaves the operator's station.

Safety during installation

 Incorrectly positioned or mounted cabling can be influenced by radio signals, which can interfere with the functions of the system.

Safety during start-up

 **Danger! Risk of death or injury.** Do not start the machine's engine before the control system is mounted and its electrical functions have been verified.

Do not start the machine if anyone is near the machine.

Safety during maintenance and fault diagnosis

Before performing any work on the hydraulics control electronics, ensure that

- The machine cannot start moving.
- Functions are positioned safely.
- The machine is turned off.
- The hydraulic system is relieved from any pressure.
- Supply voltage to the control electronics is disconnected.

Safety during operation

 **RF exposure.** To avoid possible eye injury, do not look directly into the face of the radar sensor while it is in operation

1. Product Description

1.1. TGSS

The true ground speed sensor (TGSS) uses the principle of Doppler shift to determine the ground speed of the vehicle or other type of equipment. A microwave signal that is transmitted out of the sensor, reflects off the target and is received by the sensor. When the target (terrain) is moving relative to the sensor, there is a change in the frequency of the reflected signal (Doppler shift). The ground speed is calculated by measuring the change in frequency.

The TGSS is enclosed in a black plastic case, which is potted to cover the electronics. The TGSS has a short cable terminated with a connector.

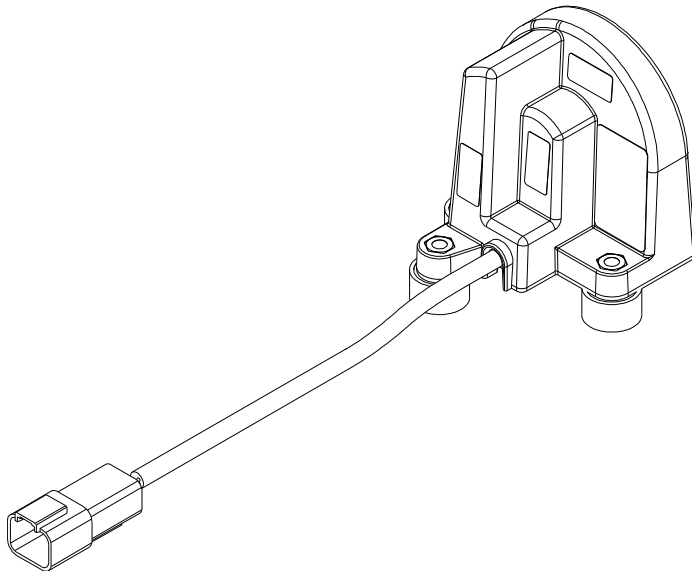

Figure 1: TGSS with Deutsch DT04-4P connector

Custom units with different cable lengths and connector types may be configured for OEM customers. Contact your Parker Vansco representative.

1.2. Compliances

This device complies with RSS 210 of Industry Canada. Operation is subject to the following two conditions: (1) this device may not cause interference, and (2) this device must accept any interference, including interference that may cause undesired operation of this device.

"Ce dispositif se conforme à la norme CNR-210 d'Industrie Canada. Les conditions suivantes s'appliquent à l'utilisation du dispositif:

(1) le dispositif ne doit pas causer d'interférence radioélectrique, et (2) le dispositif doit être en mesure d'accepter toute interférence radioélectrique, même si celle-ci est susceptible de compromettre son fonctionnement."

FCC ID: MGR740030A

This device complies with Part 15 of the FCC rules. Operation is subject to the following two conditions: (1) this device may not cause harmful interference, and (2) this device must accept any interference received, including interference that may cause undesired operation.

 Any changes or modifications not expressly approved by the party responsible for compliance could void the user's authority to operate the equipment.

Hereby, Parker Hannifin Corporation declares that the radio equipment type 740 TGSS is in compliance with Directive 2014/53/EU. The full text of the EU declaration of conformity is available at the following internet address under Product Support:

<https://ph.parker.com/us/17616/en/tgss-true-ground-speed-sensors>

2. Installation

The TGSS is typically installed at a height of 0.3 to 1 meter (1 to 3 feet) above the ground. The maximum height of installation is 1.22 meters (4 feet).

The sensor mounts to a bracket on the underside of the vehicle where the sensor may be directed in either the forward or reverse direction.

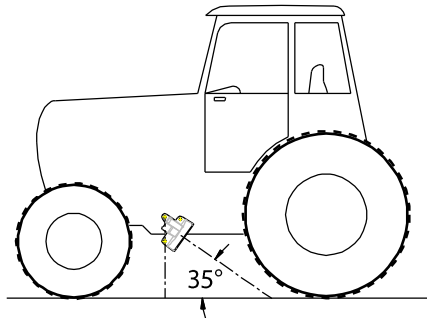

Figure 2: Typical installation

2.1. Installation Guidelines

The TGSS 740 Radar measures motion relative to itself. It is important to prevent unwanted motion in order to achieve optimal performance. The unwanted motion could be of the TGSS unit, or of an object within the radar's line of sight.

2.1.1. Mounting Bracket

The bracket should be at least 6.35 mm ($\frac{1}{4}$ ") steel and the length kept short to minimize vibration.

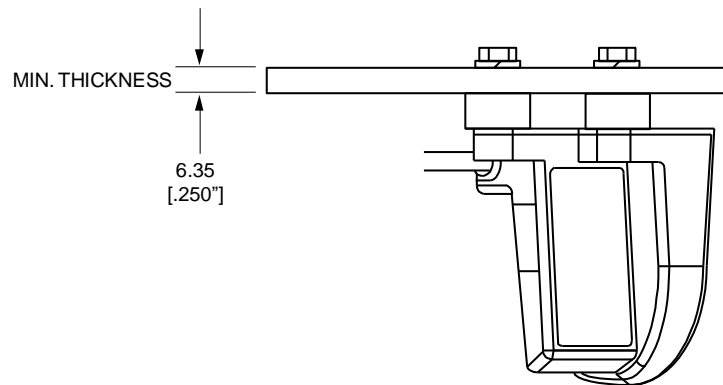

Figure 3: Mounting plate

The bracket dimensions that follow can be used as a guideline for the desired bracket size. If it is necessary to increase the dimensions, consideration should be given to increase the material thickness as well. This will help reduce the bracket's susceptibility to vibration.

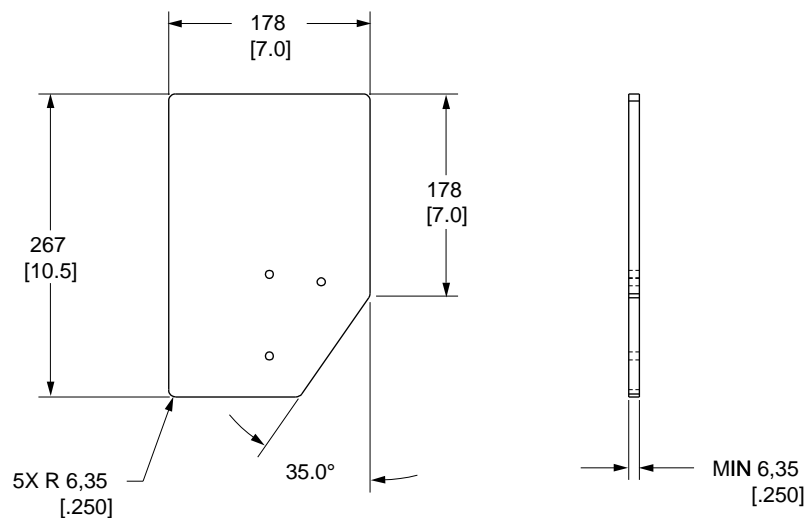

Figure 4: Recommended mounting plate dimensions

The TGSS has rubber shock absorber vibration mounts to reduce the effect of machine vibration. The vibration mounts have an internal M6 thread, the recommended installation torque is 5.4-7.3 Nm (48-65 in lbs).

2.1.2. Mounting Angle

Any error in the mounting angle will directly affect the Doppler accuracy. At 35°, an error of 1° is approximately a 1% error in speed measurement. Post installation calibration should be done to remove errors due to bracket alignment tolerances and vehicle levelness.

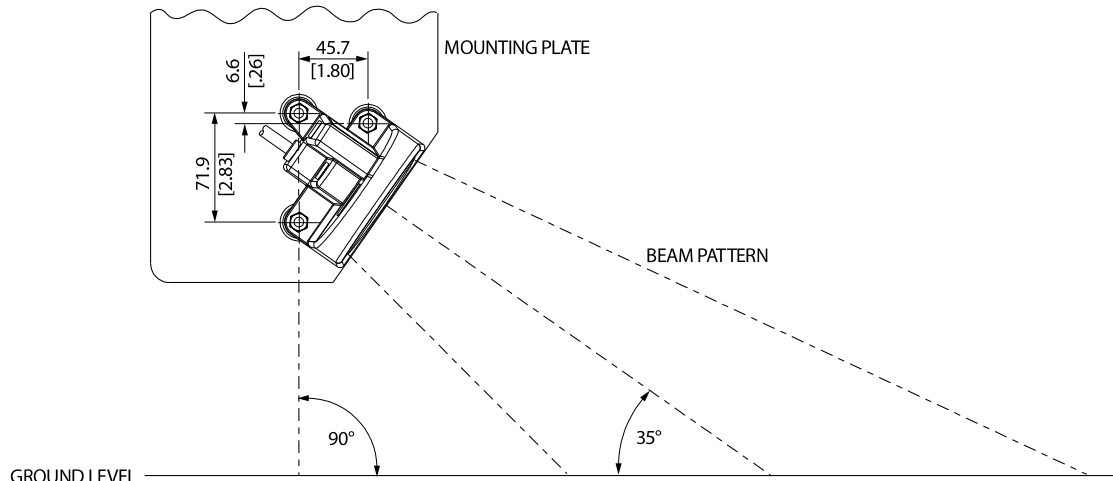

Figure 5: Installation angle

2.1.3. Mounting the TGSS to a vehicle

It is up to the original equipment manufacturer (OEM) to ensure the product is securely mounted to the vehicle.

The following guidelines are related to physically attaching the TGSS to the mounting bracket on a vehicle:

- The TGSS should be secured with **bolts in all 3 bolt holes** using 6 mm **Hex Head** bolts and locking washers.

The bolts should be tightened to 5.4-7.3 Nm (48-65 in lbs).

Appropriate length bolts are routed from the underside of the unit through the mounting plate and tightened into the shock absorbers on the unit's base. The bolts should engage the threads in the shock absorbers to a maximum depth of 6.35 mm (1/4").

2.1.4. Line of sight clearance

It is important for the sight line of the radar beam to be as unobstructed as possible. Interference with radar beam can lead to false or erratic speed readings.

The radar beam pattern is shown in Figure 5: Doppler line of sight. The smaller region is the -3dB level and the larger region is the -10 dB level. These areas are the relative sensitivity of the TGSS to motion.

The -3dB region is the area where the TGSS is most sensitive. This path must be clear of any objects. Interference in this area will have a high likelihood of degrading the performance of the product's ability to provide accurate speed measurement.

The larger -10dB region is a lower sensitivity area. Objects that interfere in this area have a potential to be an issue.

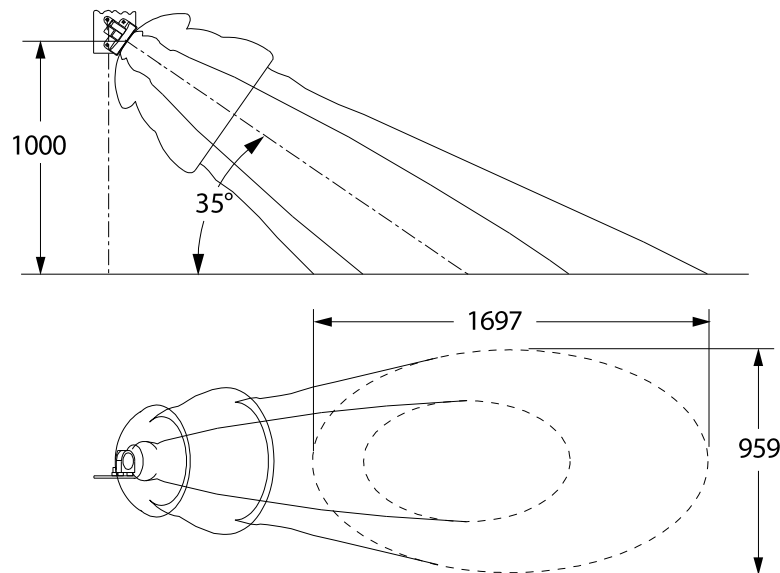

Figure 6: Doppler line of sight



Information

It cannot be known with certainty if there is a problem introduced from an obstruction in the -10 db area, because there are too many other parameters that come into play (ground texture, reflection coefficient of interference, vibration level of interference, etc.). The best practice is to design the mount so that there is plenty of clearance for the radar line of sight.

The model is based on a mounting height of 1 meter. Any other height will require that the radar beam model be stretched ratiometrically with the new height. This is done by looking at the model as spherical coordinates and scaling the radius proportionally to the 1 meter in the model.

2.1.5. Installation Validation

After an installation location has been determined, the TGSS needs to be mounted and evaluated to see if the Doppler signal is of acceptable quality.

The strength of the signal reflected back to the radar is determined mainly by the texture of the ground. The more irregular the surface, the higher the return signal. This is due to a greater reflecting area. On a very smooth surface, most of the signal is reflected away from the radar.

2.1.5.1. Line of sight evaluation

With the vehicle stationary over a smooth surface, slowly sweep the engine rpm over it's range.

Monitor the TGSS speed output to see if any false speed is shown. If a false speed reading occurs, there is either a line of sight or vibration issue.

2.1.5.2. Vibration analysis

In order to determine if the mounting has vibration, the vehicle should be positioned over a rough surface. With the vehicle stationary, the engine rpm should slowly be ramped through its range. Monitor the radar output speed to determine if different rpm are causing a vibration induced speed.

If there is vibration induced speed, it can be from two sources:

1. Excess vibration motion of the radar.
2. Something vibrating within the radar's line of sight.

If the false speed occurs on a smooth surface as well, it is likely that there is a line of sight issue.

If the problem has been determined to be due to excessive vibration on the radar mount, the vibration source needs to be reduced or high vibration isolation is required. Possible things to investigate are:

1. Add extra weight to the radar mount to increase its isolation from vibration.
2. Add vibration isolation to the mounting bracket installed on the vehicle.
3. Relocate the radar to an area of lower vibration.

 It is not required, but is suggested that the user interface that is displaying the TGSS signal be configured to ignore any data when the vehicle is stationary. This will prevent undesired speed readings caused by external sources.

2.2. Performance Considerations

The TGSS is a K Band radar. There are many factors that may influence its operation.

- The further the ground is from the radar, the lower the return signal strength.
- Smooth surfaces will reflect less signal back, resulting in lower return signal strength
- There is no return signal over standing water. Short term loss of signal from small puddles is handled by the software. When driving over large areas of water the output speed may become erratic or drop to zero.
- External sources of motion can affect Doppler signal resulting in false speed output when stationary or increased speed output signal variation when moving.
 - ◆ Tall, blowing grass
 - ◆ Rain
 - ◆ Dripping water
 - ◆ Line of sight issue with vehicle installation (ie.hoses, tires, chassis components)
 - ◆ Inadequate vibration isolation for the application
 - ◆ Flying debris from vehicle tires



Information

Even with an ideal installation, as outlined in section 4, the above conditions can still result in undesired speed readings being displayed.

3. Technical Specifications

3.1. Microwave Output

The output field strength generated by the TGSS is within the acceptability level set by the FCC, IC, and EC.

Carrier frequency:

Standard: 24.125 GHz +/- 50 MHz

UK: 24.300 GHz +/- 50 MHz

Maximum Power: 100 mW, EIRP

Beam Width: 13° in the E -plane and 11° in the H -plane,

Side Lobes: nominal -17 dB

3.2. Speed Output Signal

The frequency of the output signal is proportional to the speed of motion. When using the standard transceiver frequency of 24.125 GHz, the frequency will be 58.9Hz/mph at 35° mounting angle.

The equation for Doppler shift frequency (f_d) is given by

$f_d = 2V \frac{(f_0)}{c} \cos \Phi$	where	V = target velocity (mph)
		f_0 = transceiver frequency (Hz)
		c = speed of light (671×10^6 mph)
		Φ = angle between beam and path of target (degrees)

The sensor has the capability of scaling the output frequency. The selection is done during production by programming the scaling factor into the micro-controller.

The selectable scales are:

1. 1.0 scaling - 58.9 Hz/mph (35° mounting angle, 24.125 Ghz)
2. .75 scaling - 44.2 Hz/mph, approximately 1 pulse per cm (35° mounting angle, 24.125 Ghz)

The speed range of the sensor is 0.3 to 44 mph.

3.3. Radar-Present Output

This output signal is connected to the battery. Care should be exercised when installing the unit into a system to limit the current on this output to less than 100 mA @ 12 V.

3.4. Connectors

There are 2 standard connectors available for the TGSS. For units that do not have the Radar-present output the connector is an AMP Superseal 1.5 series, housing part number 282105-1.

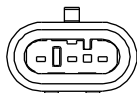

Figure 7: AMP Superseal 282105-1

AMP Superseal Connector Pinout	
Pin	Function
1	Output Speed (square wave)
2	Battery (+9 to +16 Vdc)
3	Ground

When the unit is equipped with the Radar-present output the connector is a Deutsch DT series, housing part number DT04-4P-E003.

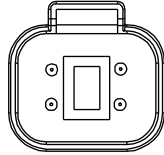

Figure 8: Deutsch DT04-4P

Deutsch Connector Pinout	
Pin	Function
1	Output Speed (square wave)
2	Ground
3	Battery (+9 to +16 Vdc)
4	Radar-Present (battery voltage)

Custom units with different cable lengths and connector types may be configured for OEM customers. Contact your Parker Vansco representative.

4. Electrical Specifications

4.1.1.1.1. Power supply requirements

Parameter	Value
Operating voltage	+9 to +16 Vdc
Operating current	120 mA @ 12 Vdc, typical
Circuit protection	Current limiting device (fuse) of 5A should be installed

4.1.1.1.2. Output signal

Parameter	Value
High state	$VOH \approx VDC_{input} - 0.6V - (IOH(mA) \times 1k\Omega)$
	$IOH_{max} \approx 16mA$ (Source)
Low state	$VOL \leq 1.0 V$ at 10 mA
	$IOL_{max} \approx 35mA$ (Sink)

5. Environmental Specifications

The 740 TGSS conforms to the requirements of:

- ASAE EP455 FEB 2003: “Environmental Considerations in the Development of Mobile Agricultural Electrical/Electronic Components”.
- ISO EN 14982: "Agricultural and Forestry Machinery - Electromechanical Test methods and acceptance criteria".

Refer to Appendix A for a complete list of specifications.

6. Mechanical Specifications

Weight: Approximately 460 gms with cable

Materials: Enclosure, black Xenoy

Cable: Water resistant, 18 AWG 4/C, SJOW

6.1. Dimensions

The following diagram shows the dimensions of the TGSS:

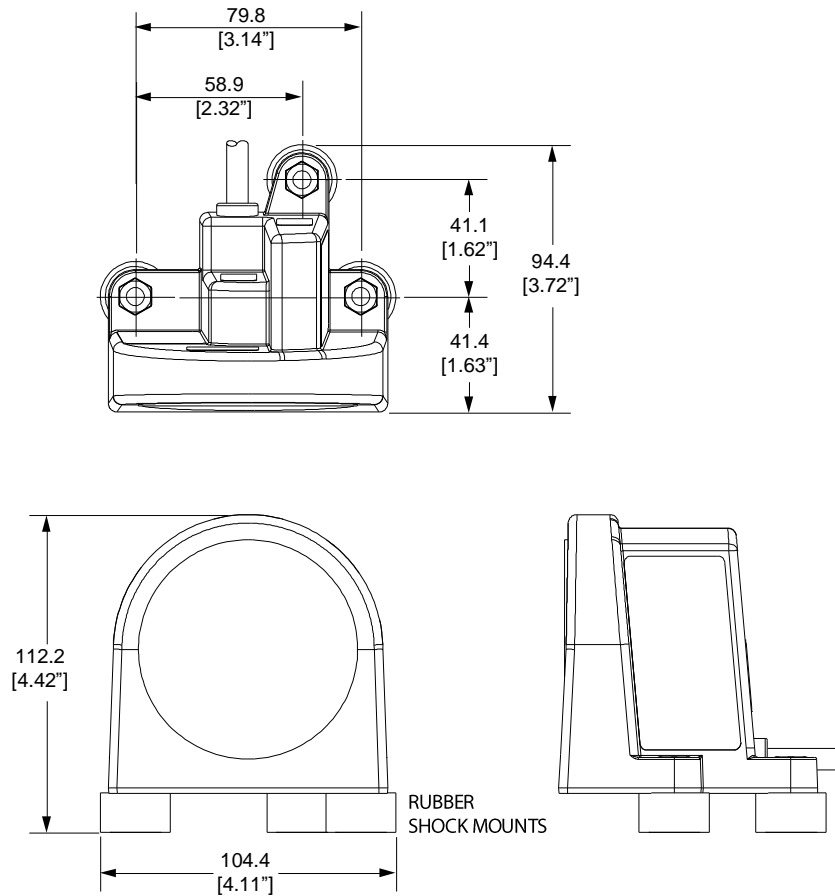

Figure 9: Dimensions of the TGSS

7. Appendix A

7.1. TGSS Technical Overview

7.1.1. Environmental ratings

Ref. #	Test Specification EP455_Jul 91	Test Description	Dev. Y/N	Notes
1.	Section 5.1.1 Level-2	Operating Temperature	Y	I
2.	Section 5.1.3	Thermal Shock	N	J
3.	Section 5.1.2 Level-2	Storage Temperature	Y	G
4.	Section 5.13.1	Humidity Exposure	N	
5.	Section 5.13.2	Humidity Soak	N	
6.	Section 5.2.2	Altitude, Storage	N	
7.	Section 5.9 Level-2	Salt Exposure	N	
8.	Section 5.8.2	Chemical Exposure	N	
9.	Section 5.6 Level-2	Sealing Tests – Hose wash	N	
10.	Section 5.6 Level-1	Sealing Tests – Pressure wash	N	
11.	Section 5.15.1	Section 5.11.4 Level-2	Y	F
12.	Section 5.14.1	Mechanical Shock	Y	E
13.	Section 5.14.2.2 Level-1	Mechanical Handling Shock	Y	C
14.	Section 5.17	Combined Environment	N	
15.	Section 5.10.1 Level-1	Operating Voltage	N	
16.	Section 5.10.2 Level-1	Steady State – Over Voltage	N	
17.	Section 5.10.7	Power-Up Operational Requirements	N	
18.	Section 5.10.3	Steady State Reverse Polarity	N	
19.	Section 5.10.4	Steady State Short Circuit Protection	N	
20.	Section 5.11.1	Transient Accessory Noise	N	
21.	Section 5.11.4 Level-2	Transient Inductive Load Switching Power Lines	Y	B
22.	Section 5.11.5 Level-2	Transient Load Dump	Y	A
23.	Section 5.11.6.1 Level-1	Transient Mutual Coupling Power Source Lines	N	

24.	Section 5.11.6.2	Transient Mutual Coupling Signal Lines	N	
25.	Section 5.16.1	EMC Immunity to radiated EM field	Y	L
26.	Section 5.16.3	EMC Emissions	Y	M
27.	Section 5.12 Level-2	Electrostatic Discharge	Y	K
28.	Section 5.7	Particle Impact	Y	D

7.1.1.1. List of Deviations

7.1.1.1.1. A- Transient Load Dump

Transient Parameter	EP455 Requirement	Test Performed
Voltage Amplitude (Vs)	106 Volts	100 Volts
Source Impedance (Ri)	2.5 Ω	2 Ω
Pulse Duration (td)	188 ms	400 ms
Cycles	5	5

7.1.1.1.2. B- Transient Inductive Load Switching Power Lines

Transient Parameter	EP455 Requirement	Test Performed
Pulse Amplitude (Vs)	-300 Volts	-500 Volts
Source Impedance (Ri)	20 Ω	10 Ω
Pulse Duration (td)	1 ms	2 ms
Cycles	300	300

7.1.1.1.3. C- Mechanical Handling Shock

The test was performed with a drop distance of 1000 mm. It exceeded the EP455 requirement of 400mm.

7.1.1.1.4. D- Particle Impact

Samples were tested using an alternate method dropping the gravel from a height of 3.7m above the surface under test. The gravel was guided by a 3m long 12.7cm diameter tube, which has its outlet 0.7m above the surface under test.

7.1.1.1.5. E- Mechanical Shock

Each sample was subjected to 100 applications of 400 m/sec² 6 msec shock pulses on each axis. EP455 calls for application of a single 490 m/sec² 11msec half-sine pulse on each axis.

7.1.1.1.6. F- Random Vibration

EP455 requirement calls for 2h minimum in each of 3 orthogonal axes at 52.4 m/s 2 RMS overall acceleration and power spectral density of $2m \ 2 / s \ 3$ from 50 Hz to 2000 Hz, it was performed for 24 hours per BS 7691 (1994).

Frequency	PSD level
10	.005 g ² /Hz
200	.020 g ² /Hz
300	.010 g ² /Hz
350	.002 g ² /Hz

7.1.1.1.7. G- Storage Temperature

1. The samples in this test were subjected to -40°C for 24 hours and then to +85°C for another 24 hours for a total soak time of 48 hours. ASAE EP455 calls for a minimum soak time of 4 hours at each extreme temperature. Transition from one temperature to another was not controlled. Effects of sudden temperature changes were performed in a separate test.
2. Power was applied to the samples throughout the test with functional verification being performed before the end of the elevated and reduced temperatures.

7.1.1.1.8. I- Operating Temperature

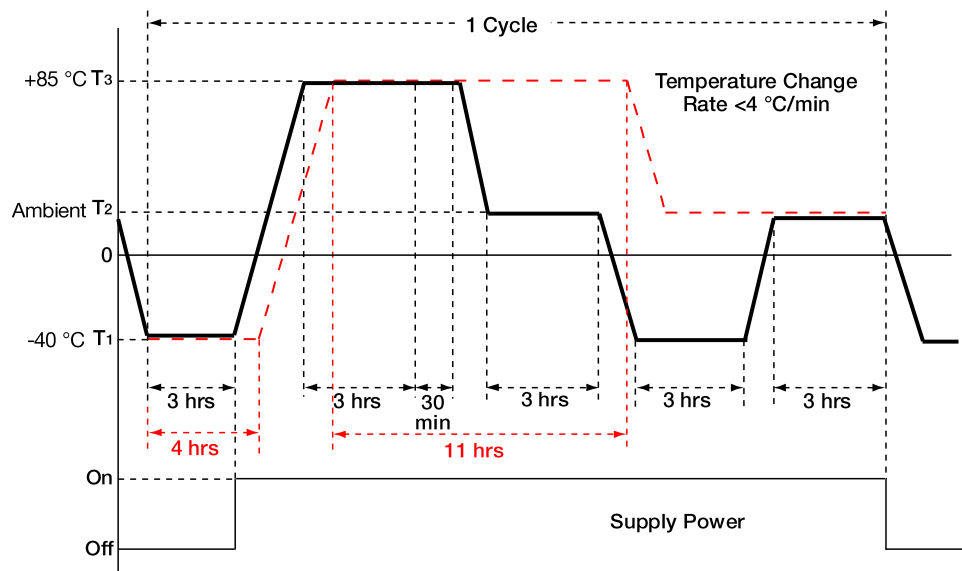

1. The samples underwent 10 cycles while EP455 requires 1 cycle only.
2. Power was applied as indicated on the figure above, while EP455 required application of power throughout the test.
3. Samples were functionally tested after soaking and while still at extreme temperatures.

7.1.1.1.9. J- Thermal Shock

Parameter	EP455 Requirement	Test Performed
High temperature	+70 °C	+85 °C
Low temperature	-40 °C	-40 °C
Soak time	1 hour	1 hour
Cycles	1	10
Transfer	4 °C/min	>1 °C/min

1. EP455 Thermal Shock test parameters with the actual test performed are shown in table above.
2. Utilized 2 chambers to achieve fast temperature transitions of less than 1 minute from one temperature extreme to another.

7.1.1.1.10. K- Electrostatic Discharge

1. The unit is not designed to withstand an ESD ± 15 kV. ± 8 kV was used for each point of discharge with the exception of the radome where the value used was ± 6 kV.
2. Each ESD was delivered using the contact method as opposed to the air discharge method specified in the EP455 document.
3. It is generally accepted that all else being constant, ESD delivered by contact method is harsher compared to one delivered by air discharge method.

7.1.1.1.11. L-EMC –Immunity

1. Subject UUT to electromagnetic fields from 20 MHz to 1 GHz with field strength of 100 V/m.
2. EMC room geometry slightly smaller than referenced specification recommends.
3. Used a stripline antenna.

7.1.1.1.12. M-EMC – Radiated Emissions

1. Measure the UUT emissions from 20 MHz to 1 GHz frequency range.
2. EMC room geometry slightly smaller than referenced specification recommends.

8. Index

A

Appendix A • 24

C

Compliances • 9

Construction regulations • vi

D

Dimensions • 23

E

Electrical Specifications • 20

Environmental Specifications • 21

G

General safety regulations • v

I

Installation • 10

Installation Guidelines • 10

Installation Validation • 15

L

Line of sight clearance • 13

M

Mechanical Specifications • 22

Mounting Angle • 12

Mounting Bracket • 11

Mounting the TGSS to a vehicle • 12

P

Performance Considerations • 16

Product Description • 8

Publication History • iii

S

Safety • v

Safety during installation • vi

Safety during maintenance and fault diagnosis • vii

Safety during start-up • vii

Safety symbols • v

T

Technical Specifications • 17

W

Welding after installation • vi



True Ground Speed Sensor
TGSS User Guide
MSG33-5005-IB/US